



Digital Clamp Meter

User Manual

■ CM240

WWW.OWON.COM.CN

Mar. 2016 edition V1.2

Copyright © LILLIPUT Company. All rights reserved.

The LILLIPUT's products are under the protection of the patent rights, including ones which have already obtained the patent rights and those which are applying for. The information in this manual will replace all that in the materials published originally.

The information in this manual was correct at the time of printing. However, LILLIPUT will continue to improve products and reserves the rights to change specification at any time without notice.

OWON[®] is the registered trademark of the LILLIPUT Company.

Fujian LILLIPUT Optoelectronics Technology Co., Ltd.

No. 19, Heming Road

Lantian Industrial Zone, Zhangzhou 363005 P.R. China

Tel: +86-596-2130430

Fax: +86-596-2109272

Web: www.owon.com.cn

E-mail: info@owon.com.cn

Table of Contents

Instruction	1
Check the Accessories	1
Safety Information.....	1
Electrical Symbols.....	3
Front Panel Description	3
LCD Display Symbols.....	4
Button Function and Auto Power Off	4
Making Measurements.....	5
Measuring DC Voltage	5
Measuring AC Voltage.....	6
Measuring Resistance.....	7
Testing Diode	7
Testing Continuity	8
Measuring AC Current.....	9
General Specifications.....	9
Electrical Specifications	10
Replacing the Batteries.....	12

Instruction

CM240 digital clamp meter is a $3\frac{1}{2}$ - digit LCD multi-meter with steady operations, fashionable structure and highly reliable measuring instrument. The meter uses large scale of integrated circuit with double integrated A/D converter as its core and has full range overload protection. The meter can perform measurements of AC and DC voltage, AC current, resistance, diode and continuity test.

Warning

To avoid electric shock or personal injury, read the "Safety Information" and "Safety Warning" carefully before using the meter.

Check the Accessories

Open the package case and take out the Meter. Check the following items carefully to see any missing or damaged part:

Item	Description	Quantity
1	User Manual	1 piece
2	Test Lead	1 pair

In the event you find any missing or damage, please contact your dealer immediately.

Safety Information













This digital clamp meter has been designed according safety standard IEC-61010-1 and LECI010-2-032 concerning electronic measuring instruments with an over voltage category (CAT II 600V) and pollution degree 2.

Safety Warning

Safety Information

1. Read the operating instructions before using the instrument and pay particular attention to all WARNINGS and CAUTIONS in this instruction manual.
2. Be sure that the cover and the test leads of the meter are in good conditions.
3. Set the range / function switch at the correct position when measuring.
4. Make sure to insert the red and the black test leads to their appropriate jacks. The black test lead should be connected first when measuring while the red test lead should be disconnected first after measuring.
5. When the range and function changes, both test leads should be disconnected.
6. To avoid damage to the instrument, never exceed the allowable maximum input of each range.
7. Be care of electric shock hazard when the voltage to be tested is above DC 60V or AC 30V.
8. To avoid electric shock, do not open the battery compartment cover when making measurement.
9. Remove the test leads from the circuit being measured before replacing the battery.
10. Do not change the built-in circuit to avoid damage to the meter.
11. Do not use or store the instrument in an explosive atmosphere (i.e. the presence of flammable gas or fume, vapor or dust).
12. CAT II-Measurement Category II is for measurements performed on circuits directly connected to low voltage installation. (Examples are measurements on household appliances, portable tools and similar equipments.) Do not use the meter for measurements within Measurement Categories III and IV.

Electrical Symbols

	Warning		Earth Ground		Double insulated (Protection class II)
	Alternating signal test		Direct signal test		Continuity buzzer
	Diode test		Low Battery		
	AC or DC				
	Conforms to European Union directives				
	Application around and removal from HAZARDOUS LIVE conductors is permitted.				
	Capacitor				

Front Panel Description

1. Input Terminals
2. LCD Display
3. Functional Buttons (SEL/MAX/HOLD)
4. Rotary Switch
5. Trigger: press the lever to open the transformer jaw.
6. Hand Guards: to protect user's hand from touching the dangerous area.
7. Transformer Jaw: designed to pick up the AC and DC current flowing through the conductor. It could transfer current to voltage. The tested conductor must vertically go through the Jaw center.

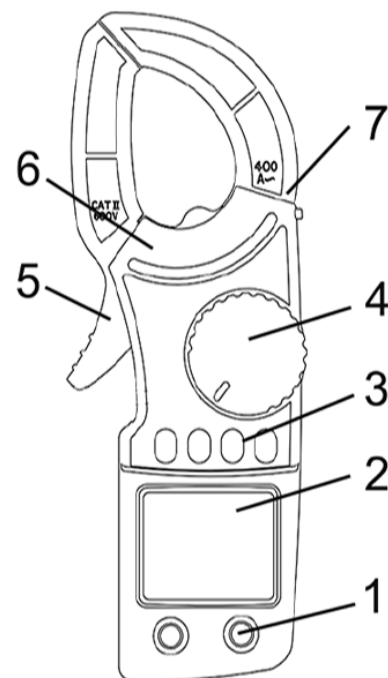

LCD Display Symbols

1. Alternating signal test
2. Direct signal test
3. Low Battery
4. Auto range mode
5. Diode test
6. Continuity buzzer
7. The maximum value is being measured
8. This indicates that the display data is being held
9. Ohms, kilo-ohms, mega-ohms resistance test
10. Amperes (current)
11. Milli-volts, volts (voltage)
12. Negative polar mark
13. "OL": The input value is too large for the selected range.

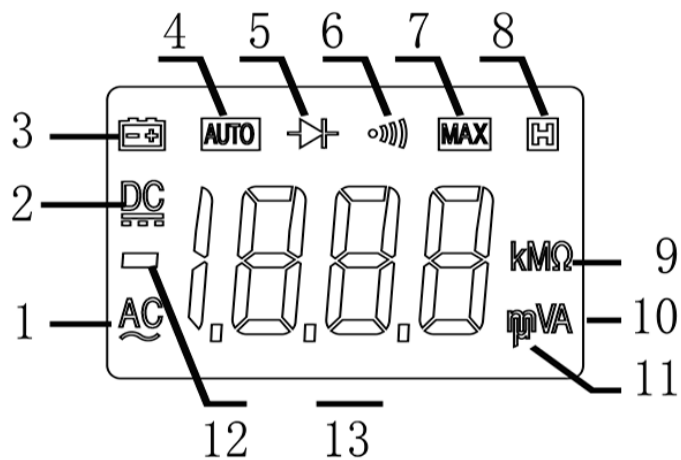

Button Function and Auto Power Off

1. **H**: For measuring data hold, press the H button, the peak value of current data will be keeping displaying on LCD; press it again to cancel this function.
2. **MAX**: Maximum data hold button, when press this button, the A/D converter will keep measuring, and the display updating the data and hold the maximum data.
3. **SEL**: Function selection button, press for switching ohm/diode/continuity function when tested objects change.
4. **Auto-power off** : If there is no any operation within any fifteen minutes after power is on, the meter will auto power off. Turn the rotary switch or press any function button to resume operation of the meter under the auto power off mode. At the same time when power on, if press the "H" button, auto power off will be disabled.

Note:

After automatic turn-off, then press **H** to re-start, the function of automatic turn-off will be cancel.

5. Buzzer

Set the selector to any measuring function (except 2/20A ACV function), press any button, the buzzer will sound; otherwise, the button is idleness. One minutes before auto power off, the buzzer continue sound in five times, and one long buzz before power off.

Note: when the selector in measuring function of 2/20A ACV, the buzzer won't sound.

6. The Effectiveness of Functional Buttons

Not every functional buttons can be used on every rotary switch positions. Below table describe which functional buttons can be used on which rotary switch positions.

Range	Functional Buttons				
	LIGHT	SEL	H	MAX	RAN
DC Voltage	●	N/A	●	●	●
AC Voltage	●	N/A	●	●	●
Resistance	●	N/A	●	N/A	●
Continuity, Diode test	●	●	●	N/A	N/A
DC current 2/20A	●	N/A	●	●	●
AC current 200/400A	●	N/A	●	●	●

Making Measurements

Measuring DC Voltage

 **WARNING**

Beware of Electrocution

Pay special attention to avoid electric shock when measuring high voltage.

Do not input the voltage which more than 600V DC.

Making Measurements

- 1) Plug the black test lead into the **COM** jack and the red test lead into the **INPUT** Jack.
- 2) Set the rotary switch to V_{DC} position to make the meter get into DC V range.
- 3) Connect the test leads to the voltage source or load terminals for measurement.
- 4) Take the reading on the LCD.

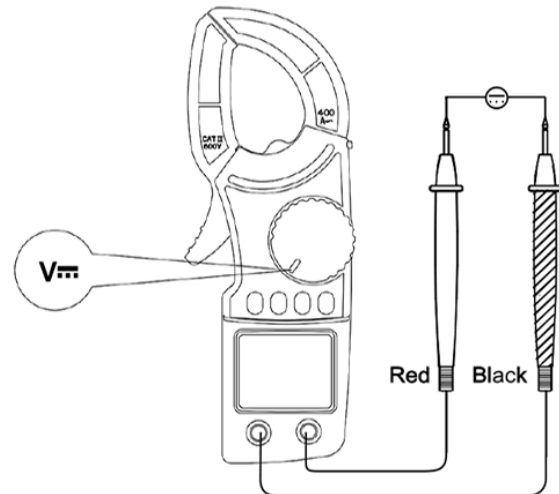

When DC voltage measurement has been completed, disconnect the connection between the testing leads and the circuit under test and remove testing leads from the input terminals.

Measuring AC Voltage

WARNING

Beware of Electrocution

Pay special attention to avoid electric shock when measuring high voltage. Do not input the voltage which more than 600V rms AC.

- 1) Plug the black test lead into the **COM** jack and the red test lead into the **INPUT** Jack.
- 2) Set the rotary switch to V_{AC} position to make the meter get into AC V range.
- 3) Connect the test leads to the voltage source or load terminals for measurement.
- 4) Take the reading on the LCD.

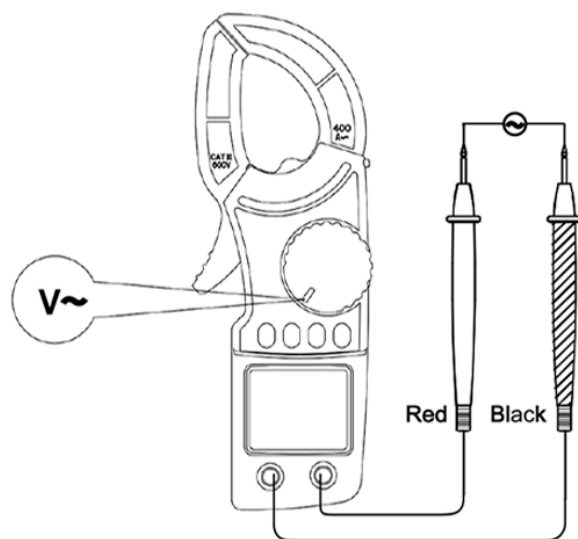

When AC voltage measurement has been completed, disconnect the connection between the testing leads and the circuit under test

and remove testing leads from the input terminals.

Measuring Resistance

⚠ WARNING

To avoid possible damage to your multimeter or to the equipment under test, disconnect the circuit power and discharge all high-voltage capacitors before measuring resistance.

- 1) Plug the black test lead into the **COM** jack and the red test lead into the **INPUT** Jack.
- 2) Set the rotary switch to Ω / \rightarrow / \bullet / \parallel range position.
- 3) Connect the test leads to the ends of the resistance or circuit for measurement.
- 4) Take the reading on the LCD.

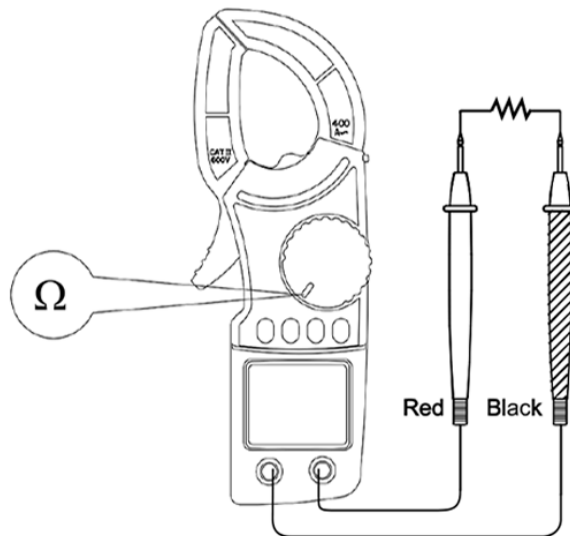

To obtain a more precise reading, you could remove the objects being tested from the circuit when measuring.

Testing Diode

⚠ WARNING

To avoid possible damage to your multimeter or to the equipment under test, disconnect the circuit power and discharge all high-voltage capacitors before testing diodes.

Making Measurements

- 1) Plug the black test lead into the **COM** jack and the red test lead into the **INPUT** Jack.
- 2) Set the rotary switch to $\Omega/\rightarrow+/\cdot|||$ range position.
- 3) Press the "SEL" button to switch to $\rightarrow+$ test.
- 4) Connect the red test leads to the anode and the black test lead to the cathode of the diode for testing.
- 5) Take the reading on the LCD.

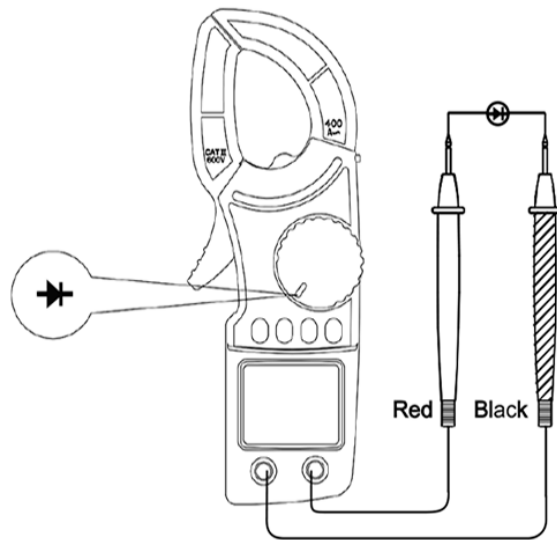

To obtain a more precise reading, you could remove the objects being tested from the circuit when measuring.

Testing Continuity

WARNING

To avoid possible damage to your multimeter or to the equipment under test, disconnect the circuit power and discharge all high-voltage capacitors before testing for continuity.

- 1) Plug the black test lead into the **COM** jack and the red test lead into the **INPUT** Jack.
- 2) Set the rotary switch to $\Omega/\rightarrow+/\cdot|||$ range position.
- 3) Press the "SEL" button to switch to $\cdot|||$ continuity test.
- 4) Connect the test leads to the ends of the resistance or circuit for measurement.

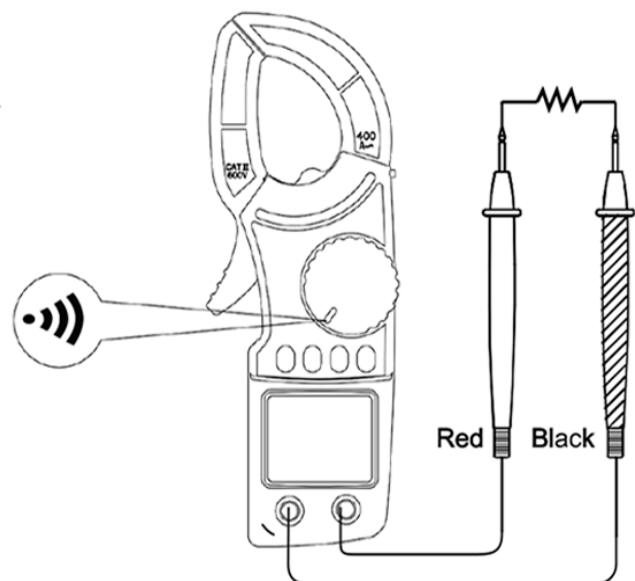

The buzzer sounds if the resistance of a circuit under test is less than 30Ω .

General Specifications

The buzzer may or may not sounds if the resistance of a circuit under test is between 30Ω to 100Ω .

The buzzer does not sound if the resistance of a circuit under test is higher than 100Ω .

Measuring AC Current

WARNING

Beware of Electrocution.

Ensure that the test leads are disconnected from the meter before making current clamp measurements.

- 1) Set the rotary switch to the $2/20\text{A}$ or $200/400\text{A}$ range position.
- 2) Press the trigger to open jaw. Fully enclose only one conductor.
- 3) Take the reading on the LCD.

Note:

- For right results, do not enclose more than one conductor in the jaw.
- For optimum results, center the conductor in the jaw.

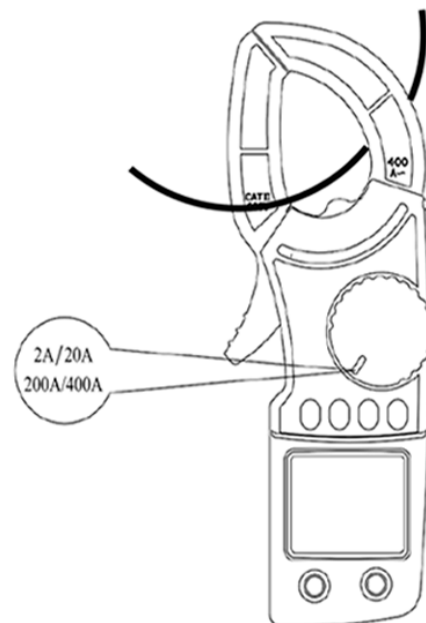

General Specifications

1. Auto range and manual range options are available.
2. Over range protection is provided for all ranges.
3. Display: $3\frac{1}{2}$ - digit (1999 count)
4. Measuring method: Dual slope integration A/D converter
5. Sampling speed: 3 time/sec
6. Unit display: Function and unit symbols displayed
7. Polarity: Automatic negative polarity display
8. Overload indication: Symbol "OL" appears on the LCD
9. Low battery indication: Symbol  appears on the LCD

Electrical Specifications

10. Auto power off time: 15 min
11. Operation temperature: 0 to 30°C (\cong 75%RH), 30°C to 40°C (\cong 70%RH), 40°C to 50°C (\cong 40%RH)
12. Storage temperature: -20°C to 60°C, \cong 75%RH
13. Operation power: Two 1.5V, AAA batteries
14. Dimension: 65mm(W) x 177mm(L) x 28mm(D)
15. Weight: 186g

Electrical Specifications

Accuracy: \pm (%reading + digits)

Operation temperature: 23°C, \leq 75%RH

1. AC Voltage: Auto Range

Range	Resolution	Accuracy	Overload protection
2 V	1 mV	\pm (1.2%+5d)	600V rms
20 V	10 mV		
200 V	100 mV		
600 V	1 V	\pm (1.5%+5d)	

Input impedance: 10 M Ω

Frequency range: 40 Hz – 1 kHz

2. DC Voltage: Auto Range

Range	Resolution	Accuracy	Overload protection
200 mV	0.1 mV	\pm (0.8%+5d)	600V rms
2 V	1 mV	\pm (0.8%+5d)	
20 V	10 mV		
200 V	100 mV		
600 V	1 V	\pm (1.0%+5d)	

Input impedance: 10 M Ω

3. Resistance: Auto Range

Range	Resolution	Accuracy	Overload protection
200.0 Ω	100 m Ω	$\pm (1.2\%+5d)$	600 Vp
2.000 k Ω	1 Ω	$\pm (1\%+3d)$	
20.00 k Ω	10 Ω		
200.0 k Ω	100 Ω		
2.000 M Ω	1 k Ω	$\pm (1.2\%+5d)$	
20.00 M Ω	10 k Ω	$\pm (1.5\%+5d)$	

4. Continuity:

Range	Resolution	Accuracy	Overload protection
•)	100 m Ω	Built-in buzzer will sound, if resistance is lower than $\leq 30\Omega$ (Open circuit voltage is about 0.45V)	600 Vp

Note:

The buzzer may or may not sounds if the resistance of a circuit under test is between 30 Ω to 100 Ω .

The buzzer does not sound if the resistance of a circuit under test is higher than 100 Ω .

5. Diode:

Range	Resolution	Accuracy	Overload protection
➔	1 mV	Displaying approximate forward voltage of diode (Open circuit voltage is about 1.48V)	600 Vp

6. AC Current: Auto Range

Range	Resolution	Accuracy	Frequency Response	Overload protection
2.000 A	1 mA	$\pm(4\%+20d) \leq 0.4A$	50 Hz - 60 Hz	400 A rms
		$\pm(3\%+15d)$		
20.00 A	10 mA	$\pm(3\%+15d) \leq 0.4A$		
		$\pm(2\%+10d)$		
200.0 A	0.1 A	$\pm(2\%+5d)$		
400 A	1 A			

Response: Average responding, calibrated in rms of sine wave

Replacing the Batteries

WARNING

To avoid electric shock, make sure that the test leads have been clearly move away from the circuit under measurement before opening the battery cover of the meter.

- 1) If the sign  appears, it means that the batteries should be replaced.
- 2) Loosen the fixing screw of the battery cover and remove it.
- 3) Replace the exhausted batteries with new one.
- 4) Put the battery cover back and fix it again to its origin from.

Note:

Do not reverse the poles of the batteries.